

Year 6 Electricity

(Physics)



Prior and future learning

Prior Knowledge	What's next?
<ul style="list-style-type: none"> I can identify common appliances that run on electricity. I can construct a simple series electrical circuit, identifying and naming its basic parts, including cells, wires, bulbs, switches and buzzers. I can identify whether or not a lamp will light in a simple series circuit, based on whether or not the lamp is part of a complete loop with a battery. I can recognise that a switch opens and closes a circuit and associate this with whether or not a lamp lights in a simple series circuit. I can recognise some common conductors and insulators, and associate metals with being good conductors. (Y4) <p>(Revision in Y5 in investigation half term)</p>	<ul style="list-style-type: none"> Electric current, measured in amperes, in circuits, series and parallel circuits, currents add where branches meet and current as flow of charge. Potential difference, measured in volts, battery and bulb ratings; resistance, measured in ohms, as the ratio of potential difference (p.d.) to current. Differences in resistance between conducting and insulating components (quantitative). Static electricity. (KS3)

Track your learning

How I will show what I have learned	☹️	😐	😊
I can associate the brightness of a lamp or the volume of a buzzer with the number and voltage of cells used in the circuit.			
I can compare and give reasons for variations in how components function, including the brightness of bulbs, the loudness of buzzers and the on/off position of switches.			
I can use recognised symbols when representing a simple circuit in a diagram.			

Key knowledge I need to understand

- Adding more cells to a complete circuit will make a bulb brighter, a motor spin faster or a buzzer make a louder sound. If you use a battery with a higher voltage, the same thing happens.
- Adding more bulbs to a circuit will make each bulb less bright. Using more motors or buzzers, each motor will spin more slowly and each buzzer will be quieter.
- Turning a switch off (open) breaks a circuit so the circuit is not complete and electricity cannot flow. Any bulbs, motors or buzzers will then turn off as well.
- You can use recognised circuit symbols to draw simple circuit diagrams.

Possible texts to read:

Goodnight Mister Tom – *Michelle Magorian*
 Blackout – *John Rocco*

Scientist: Michael Faraday
 (Invented Electromagnetic induction)

Link to maths curriculum:

- N/A

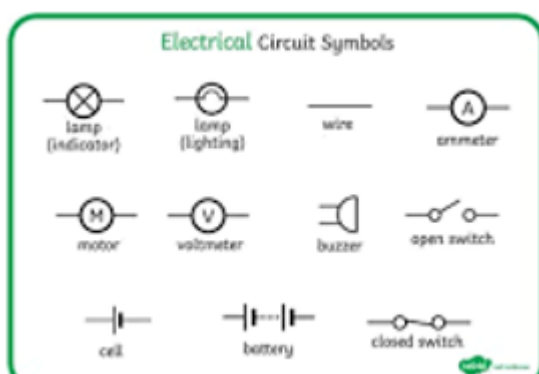

Working scientifically assessment: Bulb brightness, conductive dough

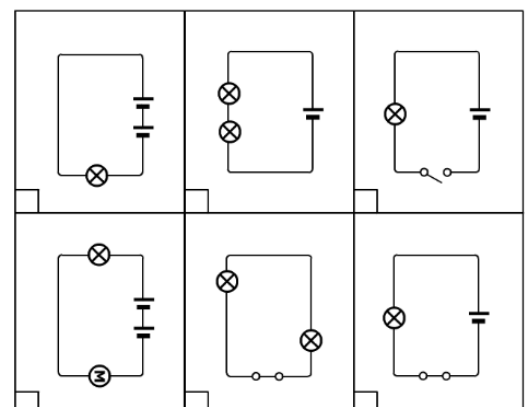

Key vocabulary I need to know

Voltage	Voltage describes the “pressure” that pushes electricity.
Circuit diagram	a simplified drawing of an electrical circuit.
Circuit symbol	The symbols used to represent the different components.
Series circuit	A circuit with bulbs next to each other, one will be dimmer than the other.
Parallel circuit	A circuit with bulbs in parallel and they will be the same brightness.
component	the parts that something is made of.